

# 60-RTU-PC3

## Uninterruptable Power Conditioner

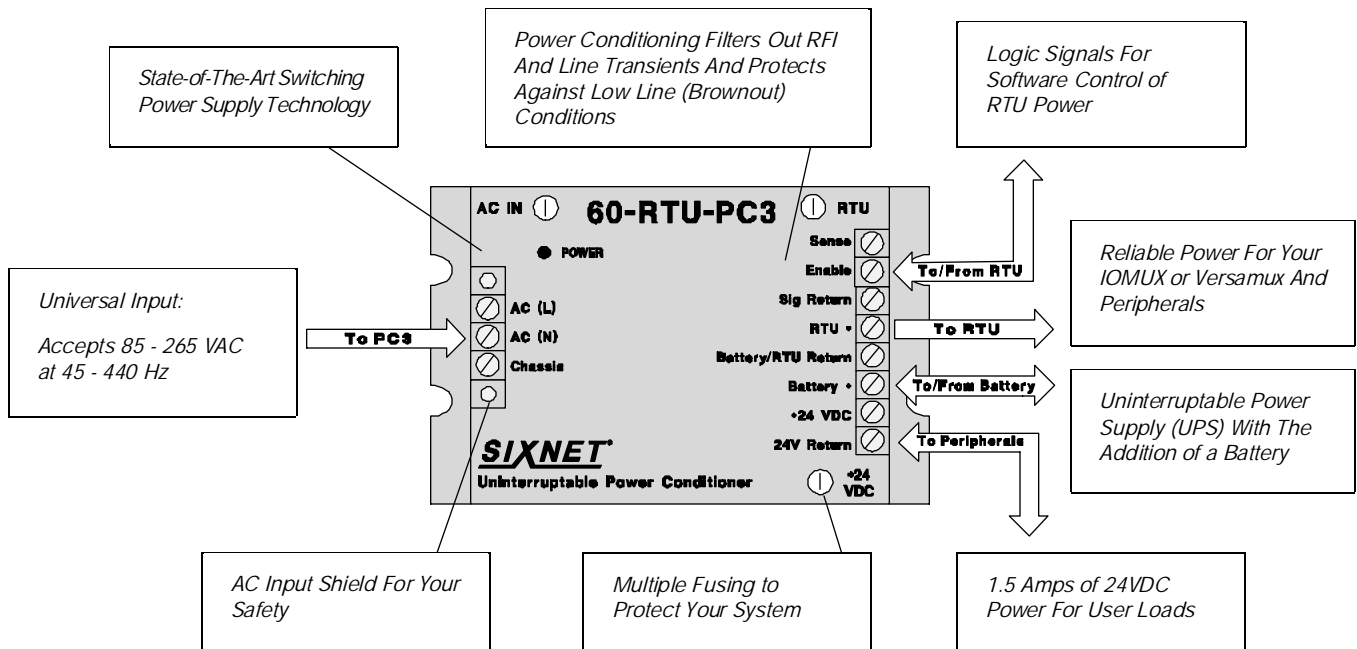

## Contents of This Manual:

		<i>Page</i>
<b>Section 1</b>	<b>Overview</b>	3
	Introduction	3
	Hardware Compatibility	3
	Software Requirements	3
<b>Section 2</b>	<b>Installation</b>	4
	Mounting Instructions	4
	Electrical Wiring	5
<b>Section 3</b>	<b>60-RTU-PC3 Operation</b>	7
	Battery Backup Power	7
<b>Section 4</b>	<b>Performance Specifications</b>	8
	60-RTU-PC3 Capabilities	8

---

## Ordering Information

Select either the standard **60-RTU-PC3** or special **60-RTU-PC3###**. Then add one or more of the battery options.

<b>60-RTU-PC3</b>	RTU power conditioner with standard 14.1 volt DC battery charging voltage. <b>Note:</b> See page 6 for custom battery charging voltages.
<b>60-BATT2.5</b>	12 volt @ 2.5 amp hour sealed-lead battery pack
<b>60-BATT8.0</b>	12 volt @ 8.0 amp hour sealed-lead battery pack
<b>60-CABLE-PC3</b>	Replacement 30 inch interface cable between the <b>60-RTU-PC3</b> and <b>SIXNET</b> controller. This cable is included with the <b>60-RTU-PC3</b> .

---

## **PROTECTED TECHNOLOGY POLICY**

**Digitronics** protects your investment in **SIXNET** systems with long-term planned technology and our unique Protected Technology Policy. We will continue to support the specified capabilities of standard **SIXNET** products for at least five years. We plan each product improvement and new feature to be upward compatible with existing designs and installations. Our goals are to make each new software release bring new power to your **SIXNET** systems and have every existing feature, applications program and data file continue to work.

We protect your investment even further with a liberal five year trade-in policy. Exchange standard products for upgraded versions of the same product to take advantage of new features and performance improvements at any time for five years. A prorated trade-in allowance will be given for your existing equipment.

**SIXNET** protects your long-term productivity with state-of-the-art planned technology and continued support.

## Introduction

The **60-RTU-PC3** enhances your **IOMUX** or **Versamux** based system with its multi-functional configuration. Using the latest switching power supply technology, it supplies and conditions DC power for your **SIXNET** system.

The **60-RTU-PC3** provides power for your **IOMUX** or **Versamux** and all expansion boards connected to it. It also supplies +24 VDC power for user loads such as 4-20 mA current loops. Power is also provided for charging an optional battery.

The **60-RTU-PC3** also gives you added protection for your industrial application. It provides filtered and conditioned power for your **IOMUX** or **Versamux** system. The incoming power is RFI (radio frequency interference) filtered and line transients are conditioned with surge suppressors. Protective fusing is also provided for the incoming AC power, the **IOMUX** or **Versamux** power, and the +24 VDC output. Furthermore, the battery charging power is current limit protected.

Add a battery to your **60-RTU-PC3** and you have an uninterruptable power supply (UPS). While AC power is present, the **60-RTU-PC3** provides a floating charge for a 12 VDC battery. Upon loss of input power, the battery automatically takes over and powers your system. The **SIXNET** controller can monitor the input power status and safely perform a controlled shutdown of the system before battery power is exhausted. Standard batteries of various amp-hour ratings are available or order your **60-RTU-PC3** for use with your own 12 volt battery.

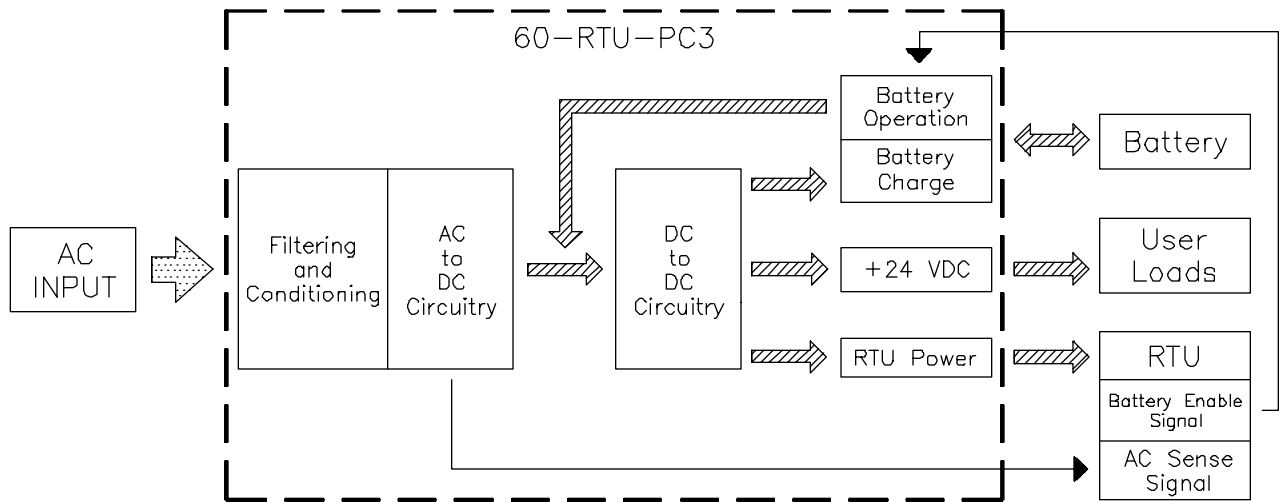

## Hardware Compatibility

The **60-RTU-PC3** may be used with **IOMUX-RTU** or **60-IOMUX-SP** controllers manufactured after July 1992, or with any **Versamux** controller. The **IOMUX-RTU** must be revision H or newer. The **60-IOMUX-SP** must be revision C or newer. Refer to the technical manual for the controller you are using. The serial number of the controller typically reflects the hardware revision.

## Software Requirements

**SCIL**, version 4.2 or later, is required to fully utilize the power control capabilities of the **60-RTU-PC3**. The `power_enable()` and `power_ok()` functions may be used to disable battery operation before battery power is exhausted, resulting in a safe shutdown of the **SIXNET** controller. Refer to Section 3 for more information on input power monitoring and battery power control.

# Section 2 Installation

## Mounting Instructions

### 60-RTU-PC3 Mounting

The **60-RTU-PC3** can be mounted to any flat surface using the mounting flanges provided. Refer to Figure 2-1 for the mounting dimensions.

**Note:** Use #6, #8 or #10 screws to mount the **60-RTU-PC3**.

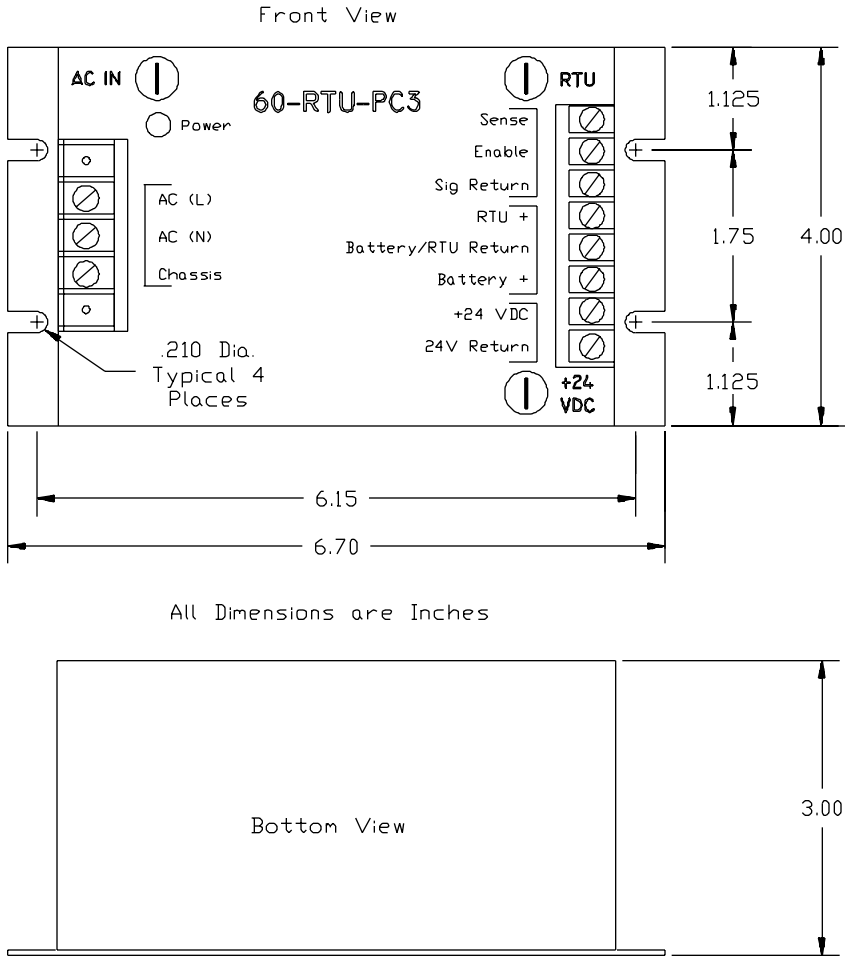

60-RTU-PC3 Mounting Dimensions  
Figure 2-1

**Battery Mounting**

The battery pack may be mounted in any convenient location near the 60-RTU-PC3. Refer to Figure 2-2 for mounting dimensions.

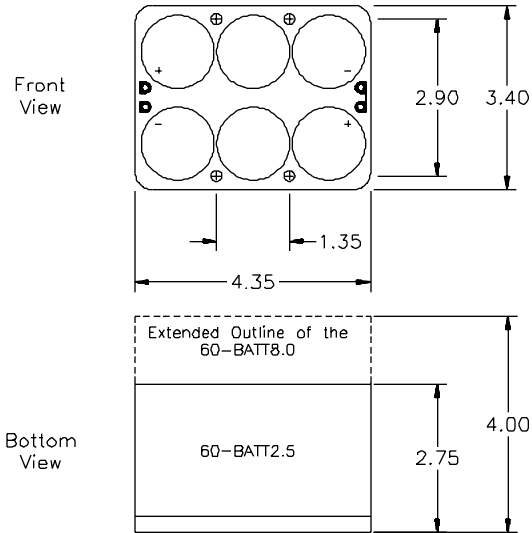

**60-BATT2.5 and 60-BATT8.0 Mounting Dimensions**  
Figure 2-2

**Electrical Wiring**

**Incoming AC or DC Power Connections**

There are screw terminals on the 60-RTU-PC3 that accept incoming 85 - 265 volt AC power. Refer to Figure 2-3 for incoming power connections. Tighten these screw terminals to a maximum of 12 in-lbs.

**Note:** It is necessary to connect AC ground to the mounting panel to ensure proper grounding. This can be done at the 60-RTU-PC3 by connecting the "Chassis" terminal to a convenient mounting screw or grounding lug on the panel.

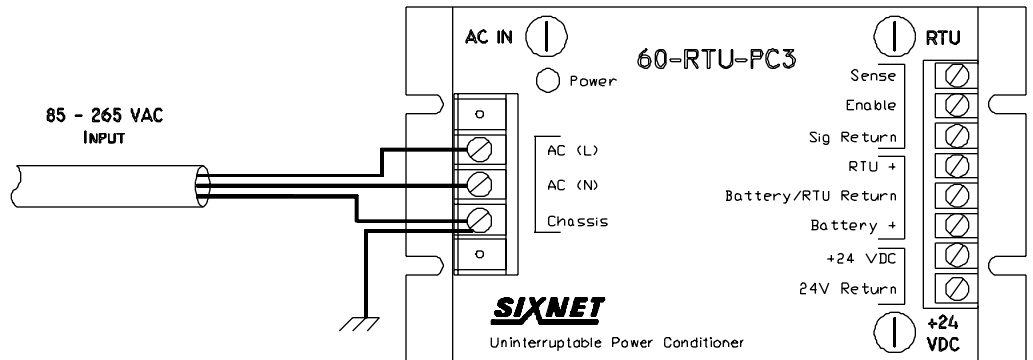

**60-RTU-PC3 AC Power Connections**  
Figure 2-3

**SIXNET Controller Power Connections**

Electrical connections between the **60-RTU-PC3** and an **IOMUX** may be made using the 30 inch wire assembly provided. Plug the end of the cable assembly with the 7 pin female connector onto the appropriate mating connector on the **IOMUX**. The individual wires on the other end of the cable connect to the screw terminals on the **60-RTU-PC3** as listed in Figure 2-4. Tighten these screw terminals to a maximum of 7 in-lbs.

If you are powering a **Versamux** controller, remove the connector from the cable assembly and strip the ends of the wires. Connections are made to the screw terminals on both devices. Cable connections are shown in Figure 2-4.

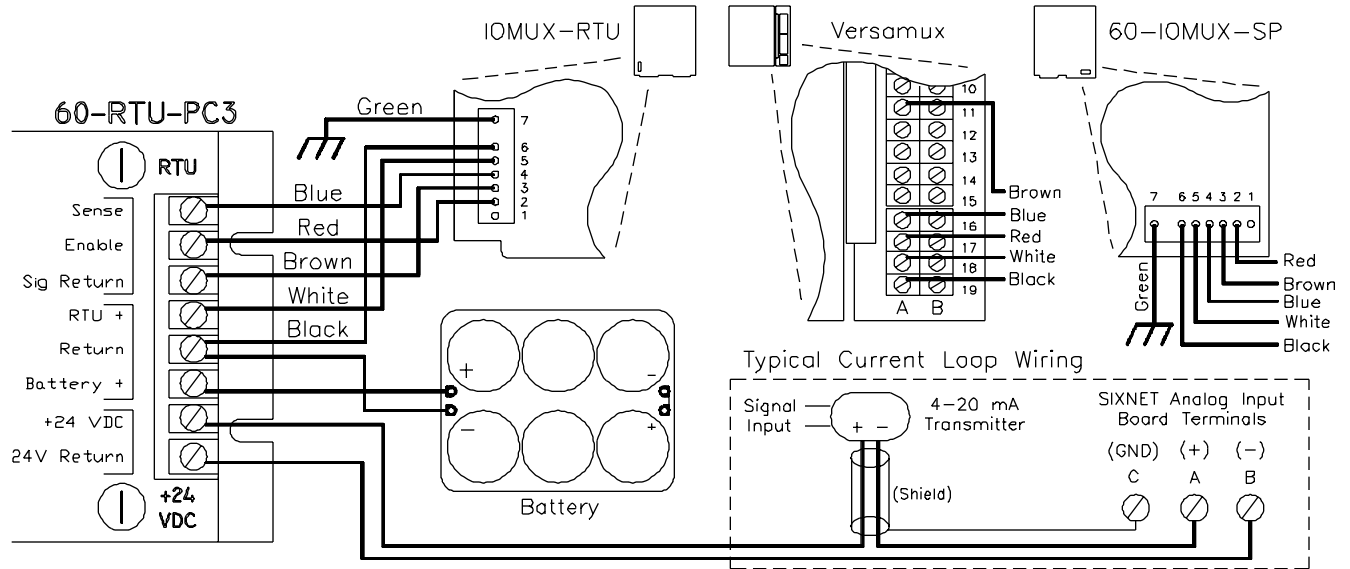

**60-RTU-PC3 DC Output Connections**

**Figure 2-4**

**User 24 Volt DC Power Connections**

Refer to Figure 2-4 for supplying 24 volt DC (user output) power to current loop devices and other low power DC peripherals. Tighten these screw terminals to a maximum of 7 in-lbs.

**Battery Connections**

Crimp style spade lugs are supplied with either battery option (**60-BATT2.5** and **60-BATT8.0**). These lugs accept 14 or 16 AWG stranded wire. Refer to Figure 2-4 for connections to the **60-RTU-PC3**.

**Paralleling Batteries**

Batteries of the same voltage and capacity may be wired in parallel to increase the battery operation period for a **SIXNET** system. Note that the recharging time for the batteries will increase, since the charging circuit in the **60-RTU-PC3** is current limited at 350 mA.

**Other Batteries**

The **60-RTU-PC3** may be special ordered to accommodate user-supplied 12 volt rechargeable sealed-lead batteries with charging voltages other than the standard 14.1 volt output. The battery charging voltage must be in the range of 12.4 volts to 15.0 volts DC. Add the charging voltage to the **60-RTU-PC3** part number. For example, a **60-RTU-PC3138** outputs a charging voltage of 13.8 volts DC.

**Battery Backup Power**

Power Monitoring and Battery Control



Battery Capacities

**Default Automatic Operation (No AC power monitoring):**

The **60-RTU-PC3** automatically provides battery operation of your system upon loss of AC power. The **SIXNET** controller firmware by default enables battery operation. When battery operation is necessary, the battery will supply power until AC power is restored, or until battery power is exhausted.

**Note:** *Controlled battery power shutdown through a **SCIL** program is recommended. Read the information below.*

**With AC power monitoring:**

In a **SCIL** applications program, the `power_ok()` function can be used to monitor the presence of AC input power to the **60-RTU-PC3**. Upon sensing the loss of input power, the `power_enable()` function can be used to terminate battery power at any time. This allows for a safe and controlled shut down of the system.

It is recommended that the battery operation period be minimized such as to not completely exhaust the battery. The maximum battery operation period depends on the battery capacity and system load.

Refer to the **SCIL** manual for details on these power control functions.

Table 3-1 below lists approximate battery operation periods for the **60-BATT2.5** and **60-BATT8.0**, under typical and full load conditions. The load conditions are defined as follows:

Typical Load = SIXNET controller load (5W) + 24VDC load (4W) = 9 watts

Max. Load = SIXNET controller load (15W) + 24VDC load (36W) = 51 watts

Actual battery operation periods will vary, depending upon the 24 VDC load and the hardware population on the **SIXNET** controller. Note that batteries may be connected in parallel to increase the operation period.

The time to fully recharge the battery (recharge period) listed for each battery type was measured after the battery was discharged for half the battery operation period.

<u>Battery Type</u>	<u>Capacity Rating (10 Hour Rate)</u>	<u>Battery Operation Period</u>		<u>Recharge Period</u>
		<u>Typical Load</u>	<u>Max. Load</u>	
<b>60-BATT2.5</b>	2.5 AH	2.0 Hours	0.25 Hour	6 Hours
<b>60-BATT8.0</b>	8.0 AH	8.0 Hours	1.0 Hour	20 Hours

60-BATT2.5 and 60-BATT8.0 Operating Periods  
Table 3-1

# Section 4

# Performance Specifications

## 60-RTU-PC3 Capabilities

The following information is typical performance data, unless designated as maximum or minimum.

AC Power Input	AC Power Requirement . . . . . 85 - 265 VAC Frequency . . . . . 45 - 440 Hz
Fuse Protection	AC Input Power . . . . . 2 Amp (Slow-blow) RTU Output Power . . . . . 3 Amp (Slow-blow) 24 VDC Output Power . . . . . 3 Amp (Slow-blow)
DC Outputs	<p><b>RTU Power Output:</b></p> Output Voltage (standard) . . . . . 14.1 VDC Maximum Output Power . . . . . 20 Watts Line Regulation (Full Range of Input Voltage) . . . . . 0.05% Load Regulation (13.8 - 14.4 VDC) . . . . . 2.0% Max. Temperature Regulation . . . . . <=1 mV / °C
	<p><b>24 Volt Output:</b></p> Output Current . . . . . 1.5A Current Limit . . . . . 3.0 ADC (Fused) Line Regulation . . . . . 0.05% Load Regulation (Full Range of Load Variations) . . . . . 1.0% Temperature Regulation . . . . . <=1 mV / °C
	<p><b>Battery Charger Output:</b></p> Output Voltage (standard) . . . . . 14.1 VDC Output Voltage range (custom) . . . . . 12.4 - 15.0 VDC Peak Charging Current (standard) . . . . . 350 mA
Miscellaneous	Operating Temperature Range . . . . . -20 to +65 degrees C Storage Temperature Range . . . . . -40 to +85 degrees C Humidity . . . . . 5 to 95% RH noncondensing Mechanical Size . . . . . 4.0W x 6.7L x 3.0H inches
Battery Specifications	<p><b>60-BATT2.5, 60-BATT8.0</b> Nominal Voltage . . . . . 12.0 VDC            Battery Type . . . . . Rechargeable Sealed-lead            Battery Capacity Rating (10 Hour Rate)                <b>60-BATT2.5</b> . . . . . 2.5 AH                <b>60-BATT8.0</b> . . . . . 8.0 AH            Required Charging Float Voltage . . . . . 13.8 - 14.4 VDC            Life Expectancy . . . . . 5 years            Cell Temperature Range . . . . . -40°C to +65°C</p>