



Interface SIXNET I/O with WWC Radio Modems

Abstract: This technical note explains the procedure used for interfacing and testing two WWC 900 SS Hopper Data Radios between a SIXNET VersaTRAK RTU and SIXTRAK Ethernet Programmable Gateway.

Radio modems provide wireless communications between SIXNET stations, and between SIXNET stations and other equipment. Radio modems can be a cost-effective solution when compared to phone/wireline, fiber optics, cable or microwave.

SIXNET successfully tested the WWC 900 SS HOPPER DATA RADIO. Discrete input/output and analog input/output signals were successfully passed from the Programmable Gateway to a VersaTRAK RTU. In a separate test, the I/O was passed from a PC to a SIXTRAK Programmable Gateway.

RS232 Cables

RADIO MODEM to SIXTRAK Programmable Gateway or VersaTRAK RTU:

The cable used for the connection is a 9-pin straight-through serial cable (DB9 male to DB9 female), such as the SIXNET VT-CABLE-MDM.

Computer to SIXTRAK Gateway or VersaTRAK RTU:

Use the SIXNET ST-CABLE-PF to load configuration settings into the SIXTRAK Programmable Gateway or VersaTRAK RTU. This cable can be purchased directly from SIXNET or your local distributor. Refer to the Gateway or RTU user manual for the pinouts of this cable.

Power Connections:

The supplied AC adapters powered the WWC radios. The SIXTRAK and the VersaTRAK were each powered by a 24 volt DC Power Supply, SIXNET part no. ST-PS-024-02N

SIXNET Serial Port Configurations

For the bench tests performed, SIXNET Universal Protocol* was used to ensure data integrity.

*Note: SIXNET stations also support Modbus ASCII protocol (as a master or slave) which is also suitable for radio communications. Modbus RTU Protocol, though supported by SIXNET stations, is not recommended for radio links.

The SIXNET Plant Floor utility was used to configure the settings shown below:

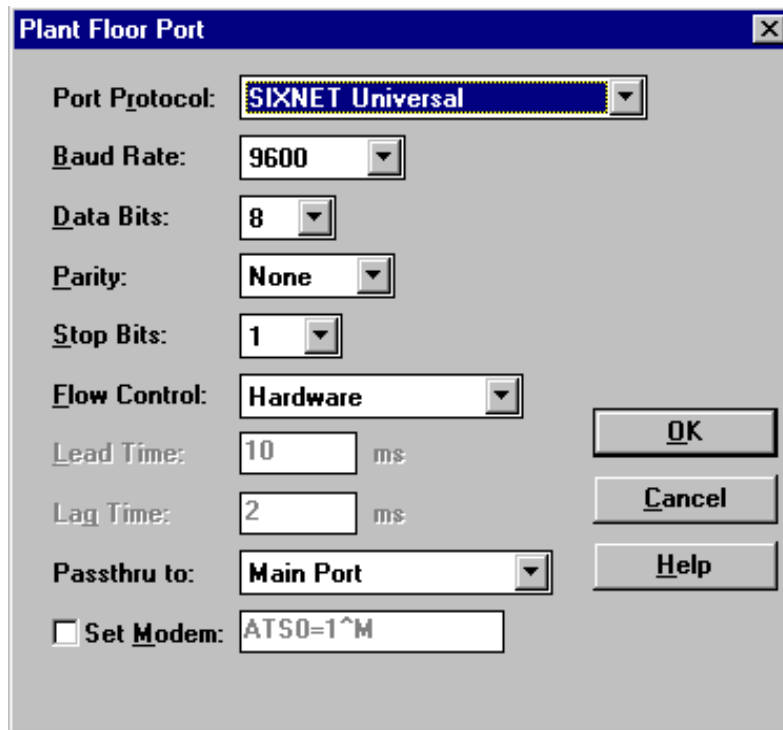

WWC 900 SS Radio Modem Communications:

The WWC 900 SS Radio Modems communicate asynchronously at a data rate of 9600 bps, using half-duplex transmission. The transmitters are keyed automatically upon receipt of command characters. Transmitter lead and lag periods are inserted automatically by the radio modems. The WWC 900 SS radio modems are considered “intelligent” because they automatically handle their transmitter keying and lead/lag times. Therefore, they are suitable to connect directly to a PC. Other radio modems that are considered “dumb” rely on the master device to control these parameters. A standard PC, by default, doesn’t do this, so it is typically not suitable for direct use with “dumb” radios.

Note: SIXNET Gateways and RTUs support both intelligent and dumb radio modems.

WWC 900 Hopper Data Radio Configurations:

No changes were required. Default configuration settings were used.

Testing on the WWC 900 Hopper Data Radio:

Two tests were performed: The first test established PC communication over the radios to a SIXTRAK Gateway. The second test performed Passthru communication over the radios to a VersaTRAK RTU.

In the initial test performed, data was passed directly from the PC to the radio modems. SIXNET Plant Floor Software was used to read and write I/O directly from the PC. Plant Floor is a configuration, calibration and maintenance tool for SIXTRAK and VersaTRAK I/O. Plant Floor is used to configure I/O features, perform channel-by-channel calibrations in meaningful engineering units, and perform live diagnostics on each station.

In the second test performed, data was passed from a PC to a Gateway and then to a VersaTRAK RTU using the radios. SIXNET Plant Floor Software was also used in this test and the SIXTRAK Gateway was set for Passthru Mode. In the Passthru Mode, SIXNET commands and data, addressed for other stations or modules, were forwarded from one communication port to another. With “dumb” radios and Passthru Mode enabled, a gateway or RTU can function as a radio modem master, thus eliminating the need for a special communication board or software in you PC. The WWC 900 SS radios are “intelligent” and will work in either scheme. For additional information on Passthru Mode: From the SIXNET CD, click Plant Floor Help, click Help Topics; **See:** [Passthru Mode Overview](#); [Enabling Passthru Mode](#).

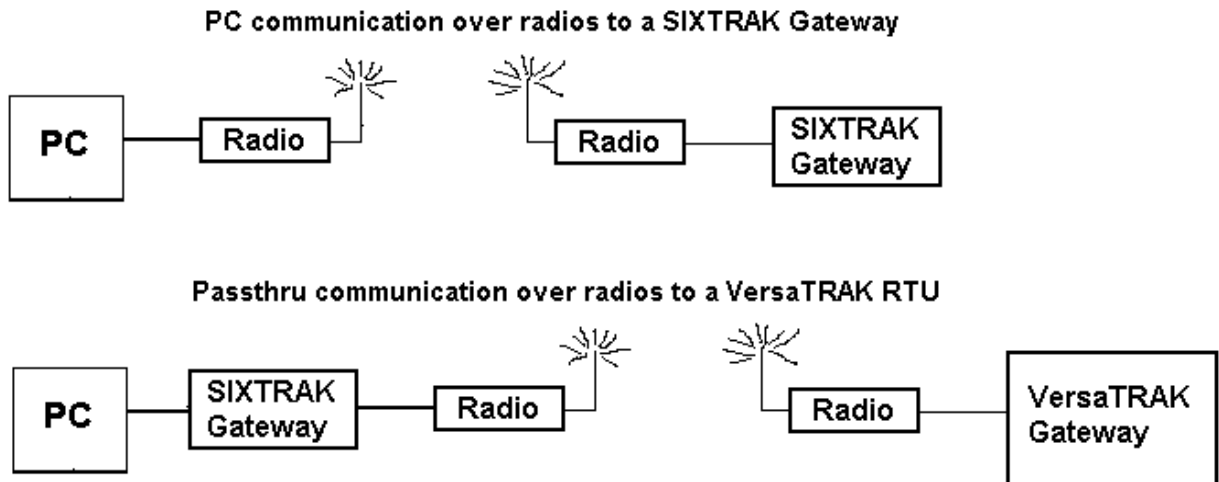

For additional information about using the WWC 900 SS Hopper Data Radio with SIXNET hardware, contact SIXNET.

For more information concerning WWC Data Radios, contact:

World Wireless Communications, Inc.
2441 South 385 West
West Valley City, UT 84120
Phone: 801-575-6600
Fax: 801-575-6621